



Refuse



Built to carry an entire industry.

Refuse is a tough business. That's why Mack® trucks are built to overcome the punishing conditions that residential, commercial and municipal refuse applications routinely dish out. Mack's long been the leader in refuse and we continue to set the standard for durable, productive and safe trucks.



The lowest total cost of ownership paired with the highest value and productivity:

LEGENDARY POWERTRAINS

Mack powertrains are the standard for performance and reliability across a wide range of applications.

TOUGH JOBS, TOUGHER TRUCKS

Our trucks stand up to the full abuse of refuse work to keep you on the job and in the black.

BY YOUR SIDE 24/7

Mack Connect, our uptime and productivity solution, brings technology and service professionals together for round-the-clock support.

PURPOSE-BUILT FOR THE JOB

Mack's experience means your truck is exactly suited to the job at hand for each refuse configuration.

SAFETY, COMFORT AND ERGONOMICS

Make sure your drivers stay safe and productive, so you can attract and retain top driving talent.

Compare	Mack	Other
Engines tuned for on- and off-highway, high horsepower, torque and low fuel consumption.	✓	✗
Rear axle with unique top-mounted carrier for a longer lifespan and superior ground clearance.	✓	✗
Automatic power divider that diverts up to 75% of power to the wheels that are not slipping.	✓	✗
Front axle with 135mm thick cross-section for high gross weights.	✓	✗
Low floor and step height for safe and easy transition in and out of the cab ¹ .	✓	✗
Heavy-duty spring suspensions that provide high ground clearance and traction.	✓	✗
"Right sized" steel cabs with short bumper-to-back-of-cab dimensions for getting in and out of tight spaces.	✓	✗
Best-in-class forward and side visibility.	✓	✗
<i>mDRIVE</i> [™] HD transmission shifts for you and saves weight and fuel ² .	✓	✗
GuardDog [®] Connect proactively monitors engine performance and alerts when there is a potential problem ³ .	✓	✗
Durable chassis frame with high-yield steel and formed steel plate crossmembers.	✓	✗

Available in: LR and Granite¹; Granite²; Granite and TerraPro³

CLEAN UP ON DIRTY JOBS.

Mack's 100-year history in refuse means our trucks are built to take a beating and boost your bottom line.



DURABILITY

Suspensions

Mack offers rear suspensions for on- and off-road refuse applications. On road, they provide better handling and traction and reduced tire wear. They also have the superior articulation and constant ground contact needed to handle rugged terrain.

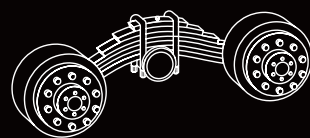

Camelback Suspension

Power Divider and Rear Axle

All Mack® rear axles feature a cam-and-wedge design with automatic power divider to divert power to the wheels with traction. A manual locking option gives you ultimate control over power distribution.

Front Axle

Our heavy-duty UniMax™ steering axles have maintenance-free sealed, unitized hubs for harsh duty cycles.

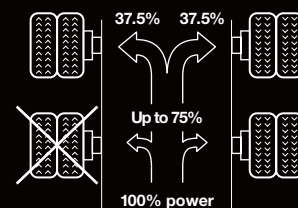

POWERTRAIN

Legendary MP® Engines

The MP®7 and MP®8 deliver power and torque across a wide range tuned for different refuse applications for faster route times and high fuel efficiency.

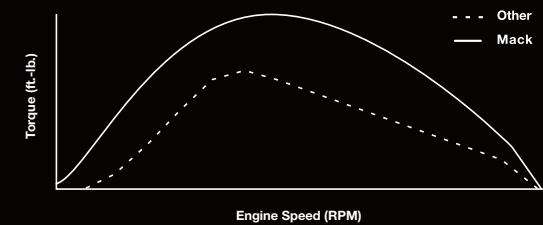

Get the right power mix for your needs. Mack's Maxidyne® engine rating has extended RPM ranges and high torque rise for rugged terrain and landfill use. MaxiCruise® offers both power and economy whether you are off-road or on-road.

Fully Integrated

Integration means our engines, transmissions and drive axles are designed to work together for maximized performance and efficiency. It also means there's only one number to call when you need help. We handle the work with no third-party suppliers, so you get back on the road faster.

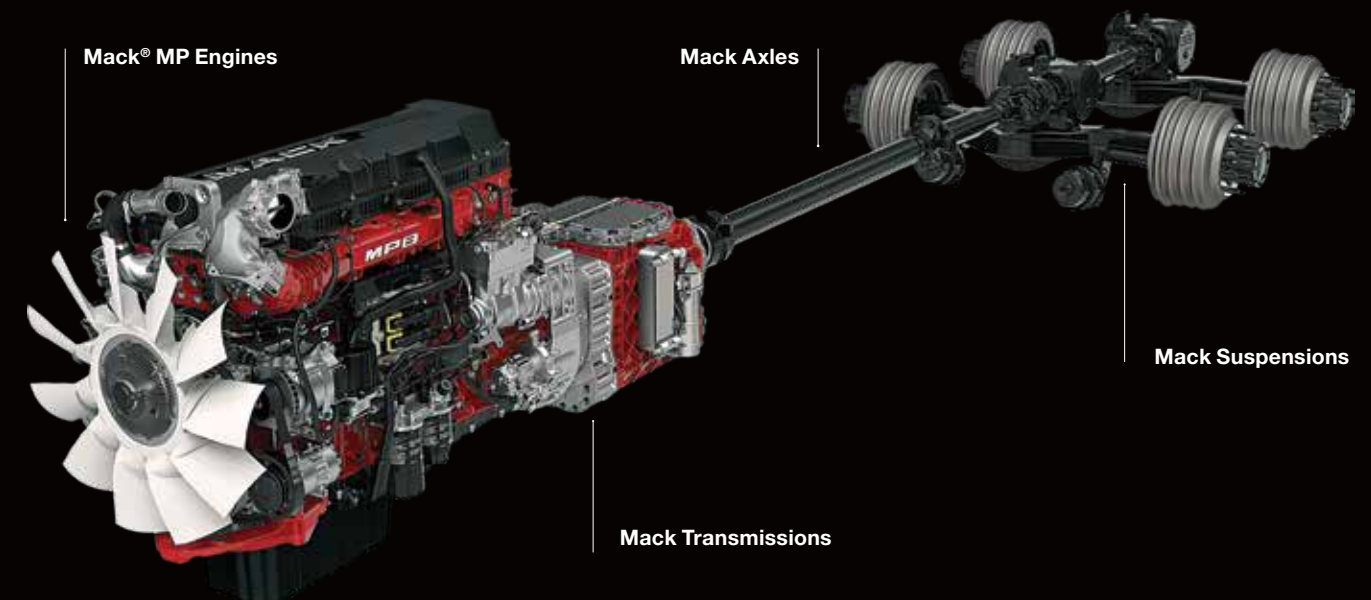

DRIVER COMFORT

Ergonomic Design

Mack takes care of the people who drive your business. Our trucks are designed from the inside out for comfort, safety and productivity. Comfortable seats, intuitive controls, factory-installed AC and convenient storage bins are just a few of our best-in-class features.

Driver Retention

Driving a refuse truck is demanding work. Best-in-class performance, comfort and safety combined with enhanced in-cab communication and superior support makes Mack the truck drivers want to drive. The result is more productivity on the job and less money spent on recruiting and training new drivers.

NATURAL GAS

Near Zero Emissions

The Cummins Westport L9N engine is a natural choice for heavy-duty vehicles like the TerraPro® and LR model. It drives emissions to near zero and brings up to 400 HP to demanding refuse jobs. Mack offers factory-installed CNG tanks with an LNG option.



MACK® REFUSE MODELS

TERRAPRO®

Alternative Fuels

TerraPro natural gas models use LNG or CNG for lower overall lifecycle and fuel costs, as well as lower greenhouse gas (CO₂) emissions and a reduced carbon footprint.

Superior Maneuverability

With a short wheelbase, slimmer width and more compact design from bumper to back of cab, TerraPro's cabover design makes navigating even the most congested neighborhoods safer and more efficient.

Maximum Viewing Angles

TerraPro's large mirrors combined with the most forward window glass in the industry creates superior visibility so you can keep pedestrians, other vehicles and side loading jobs safely in view.

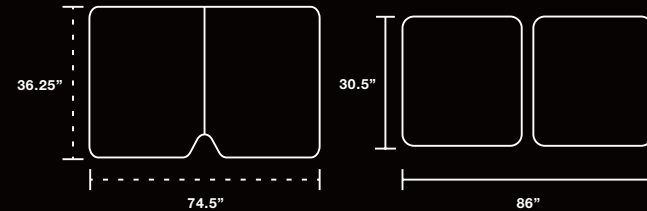

LR

One-Step Entry and Exit

Low, 17" cab floor height and large grab handles help drivers get in and out with minimal effort and reduce the physical demands of curbside pickup operations.

Multiple Door Designs

Getting in and out of the Mack LR is easy with its large doors and three door configurations.

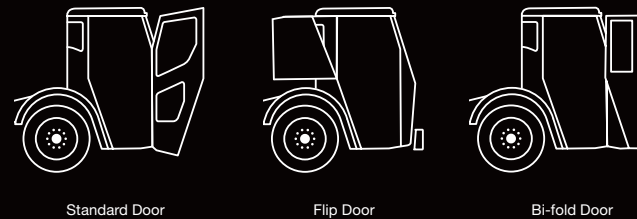

Driving Configurations

Standup or seated. Right- or left-hand or dual steering positions. LR covers them all, giving you the best choice for each job.

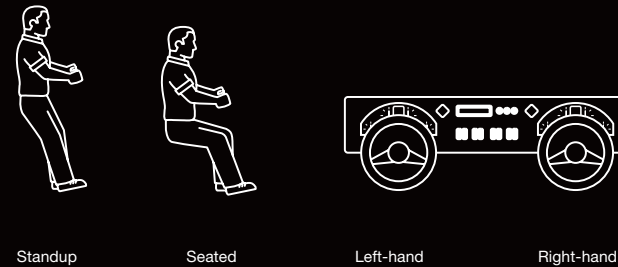

GRANITE

Redesigned Interiors

All-new interiors in the legendary Mack Granite® make it more driver friendly than ever before. With a flat-bottom steering wheel, intuitive controls and durable components, Granite keeps drivers comfortable all shift long.



Flat-Bottom Steering Wheel



Mack-Exclusive Seats

mDRIVE™ HD Automated Manual Transmission

Mack's mDRIVE HD automated manual transmission maximizes performance and fuel economy while reducing driver fatigue. mDRIVE uses intelligent software and engine integration to automatically select the best gear and seamlessly shift with speed and precision for an easy ride for you and your truck.



Improved Maneuverability

Short bumper-to-tire distance means superior front-end swing clearance and an excellent wheel cut that allows trucks to easily get in and out of tight spaces.

With Mack® Connect, it's uptime all the time.

Mack's exclusive uptime and productivity solution, Mack Connect, combines intelligent software, predictive analytics, driver assist technologies and more to help you keep your trucks—and your business—moving forward. See the complete list of Mack Connect services at MackTrucks.com/MackConnect.

800-866-1177

MACK ONECALL®
SUPPORT LINE



Over The Air (OTA)

Software and Parameters

Wirelessly updates software without disrupting your schedules, while increasing operational efficiency and uptime. Requires Mack GuardDog® Connect.

GuardDog® Connect

Automatically monitors your truck's performance and alerts OneCall of any maintenance or repair needs. OneCall's 24/7 support leverages Mack ASIST to give drivers, dealers and Uptime Center staff access to the repair information they need—all while you're still on the road.

Certified Uptime Dealers

In the heavy truck industry, the average dwell time for a repair is 4 days, but the average repair actually takes less than 4 hours. Our Certified Uptime Dealers identify the quick fixes and put them in the fast lane for completion, while giving larger repairs the attention they need.

Customize with Confidence.

- Body builder support ensures seamless communication among body builders, dealers and customers.
- We design trucks with additional access points and mounting locations for easy installation.
- Factory warranty on all customization at the Mack factory.
- Peace of mind knowing the custom job was done right by the pros at Mack.
- Engineering documentation for ease of future service and maintenance.





1-800-922-MACK
MackTrucks.com

©2019 Mack Trucks, Inc.

 facebook.com/MackTrucks

 twitter.com/MackTrucks

 youtube.com/MackTrucks

 linkedin.com/company/Mack-Trucks

 instagram.com/MackTrucks